

# FICHE TECHNIQUE

## POULIE DENTÉE

Groupe  
**01-03-04-04**

Exemple



Données client

Type machine : .....

Demande de prix

No. série machine : .....

Commande

CODE : D1 x B1 x Z x H x TY-BV x D2 x D3 x B2 x AC x AT-GA x D4 x L x TA x Pm x Pi x RH/LH

D1 ..... Diamètre poulie.

B1..... Largeur des dents.

Z..... Nombre de dents.

H..... Hauteur totale.

TY-BV ..... Type de fixation interne, voir types.

D2 ..... Dimension, voir type de fixation interne.

D3 ..... Dimension, voir type de fixation interne.

B2..... Dimension, voir type de fixation interne.

AC ..... Nombre de cannelures fixation interne.

AT-GA..... Nombre de trous de fixation.

D4 ..... Diamètre trous de fixation, si sans filetage.

L ..... Distance, voir figure.

TA ..... Filetage des trous de fixation.

Pm..... Pas métrique.

Pi ..... Pas par pouce.

RH/LH..... Filetage droit / gauche.

## DIMENSIONS

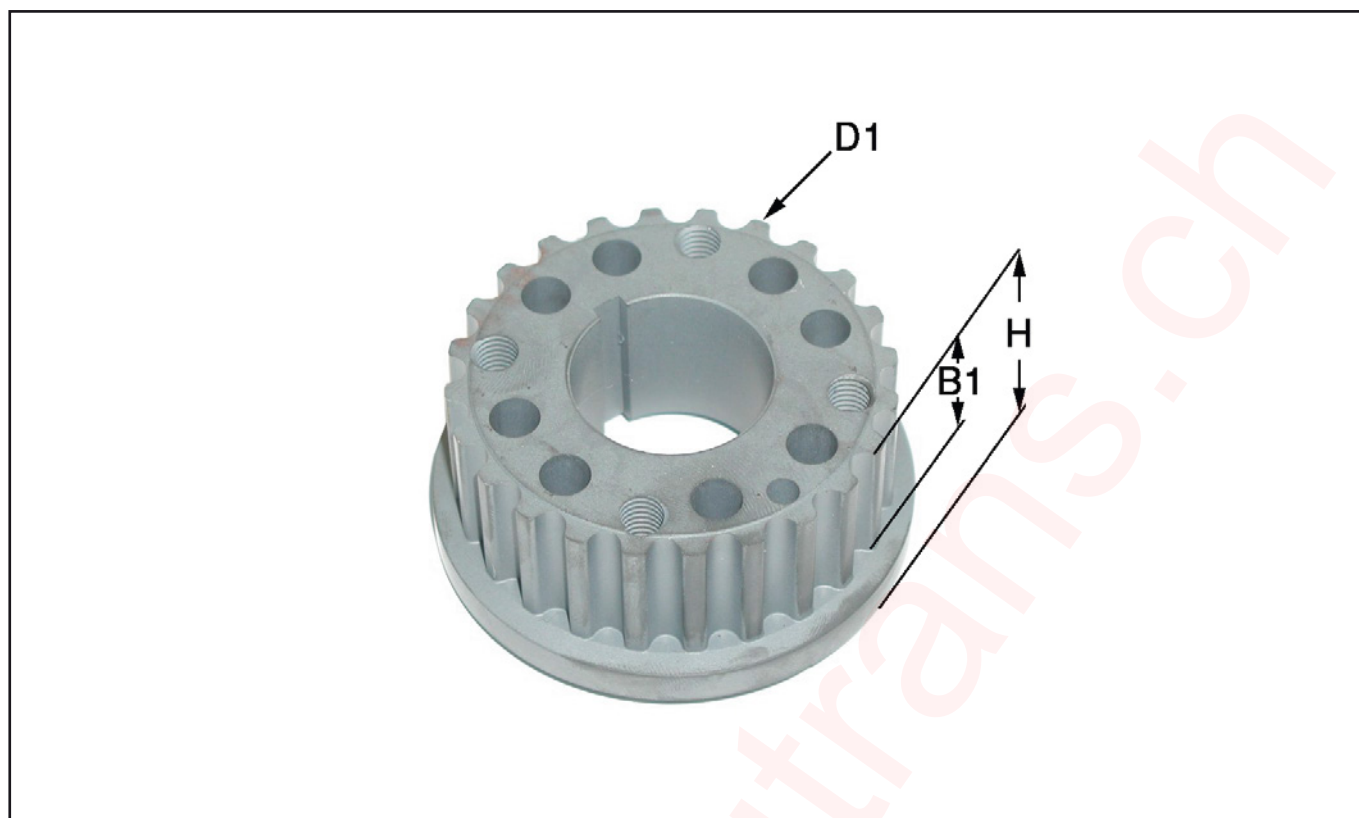

## DIMENSION TROUS DE FIXATION

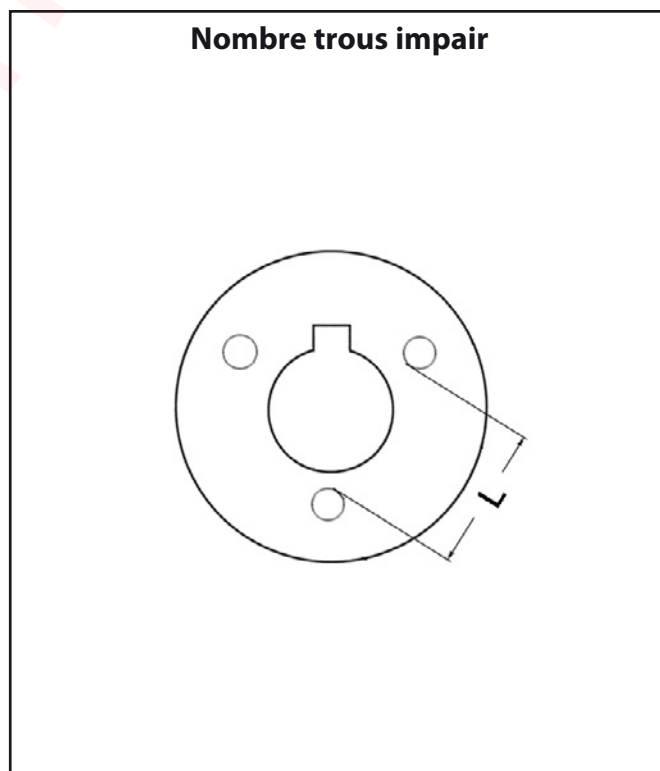
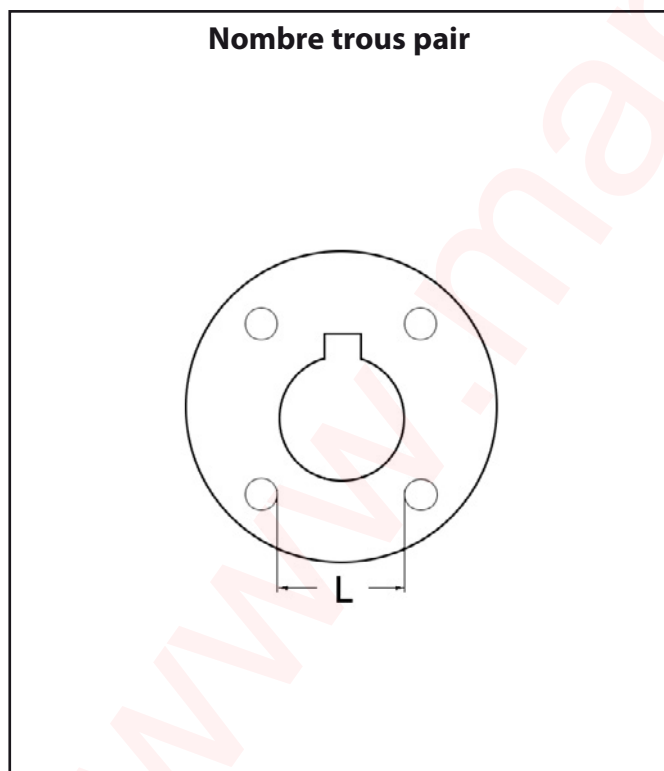

**NOTE :** ceci n'est pas la distance entraxe, mais la distance mesurée selon les schémas ci-dessus.

## TYPES INTERNES

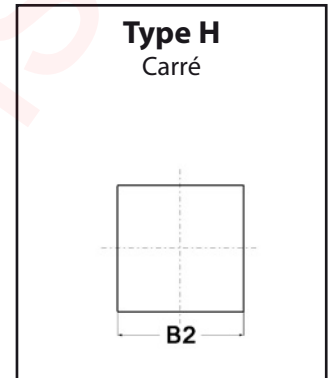
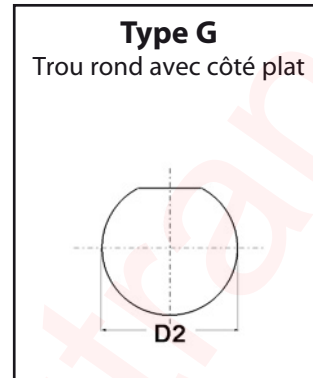
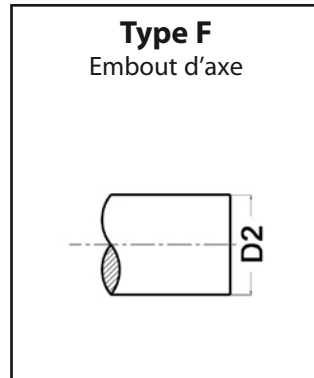
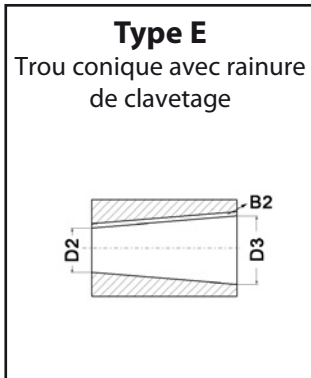
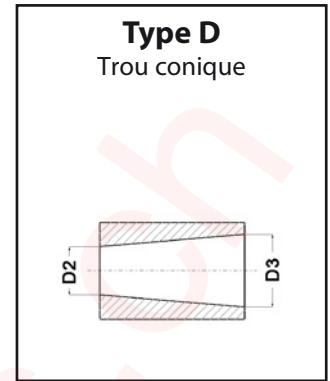
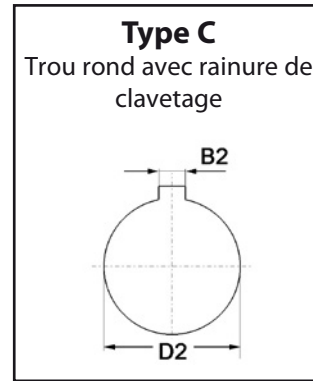
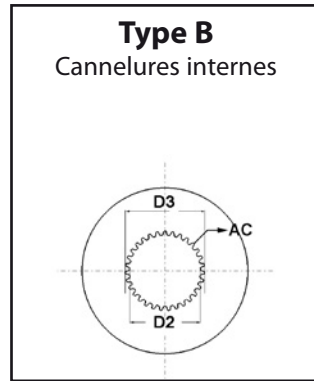
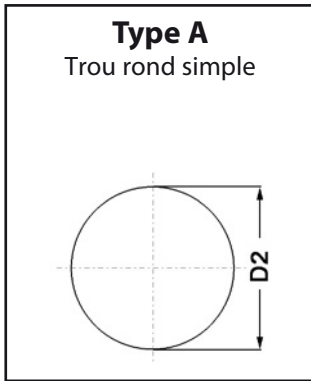

**Type S**  
Type special

S'il y a plusieurs types internes, suivre l'ordre ci-dessous : B - D - C - A - E - F - G - H.  
Ex: s'il y a présence en même temps de types D et A, remplissez D.

## MESURER

Pour la mesure d'un nombre de dents impair, nous plaçons la mâchoire fixe du pied à coulisse sur deux dents et fermons la mâchoire mobile jusqu'à ce qu'elle atteigne une dent opposée.

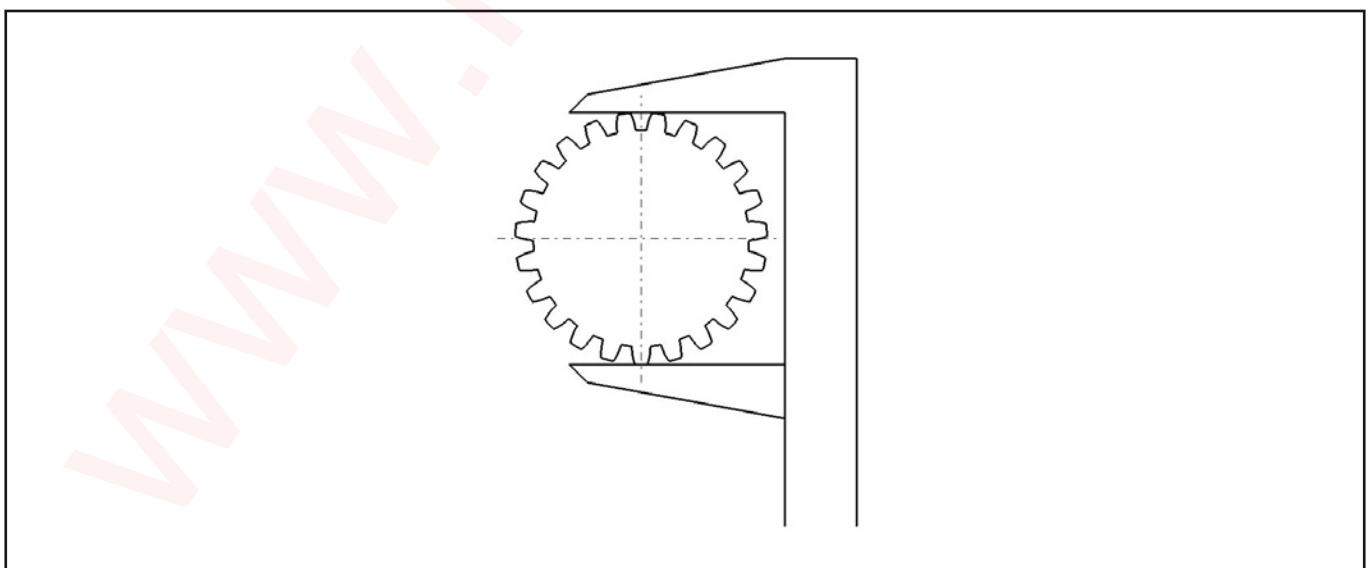

# TECHNICAL SHEET

## TOOTHED BELT GEAR

Group  
**01-03-04-04**

Example



Customer details

Type machine: .....

Price inquiry

Serial n° machine: .....

Order

CODE: D1 x B1 x Z x H x TY-BV x D2 x D3 x B2 x AC x AT-GA x D4 x L x TA x Pm x Pi x RH/LH

- D1 ..... Pulley diameter.
- B1..... Teeth width.
- Z..... Number of teeth.
- H..... Total height.
- TY-BV ..... Type of inner mounting, see types.
- D2 ..... Diameter, see type of inner mounting.
- D3 ..... Diameter, see type of inner mounting.
- B2..... Diameter, see type of inner mounting.
- AC ..... Number of splines inner mounting.
- AT-GA..... Number of mounting holes.
- D4 ..... Diameter of mounting holes, if not threaded.
- L ..... Distance, see picture.
- TA ..... Thread type of mounting holes.
- Pm..... Step (metric).
- Pi ..... Step (inch).
- RH/LH..... Right-hand or left-hand thread.



**MANUTRANS**<sup>SA</sup>

Fournitures pour engins de manutention

Manutrans SA  
Avenue de Lucens 44  
CH-1510 Moudon

Tél : +41 21 781 27 77  
Fax : +41 21 781 27 79  
info@manutrans.ch

## DIMENSIONS

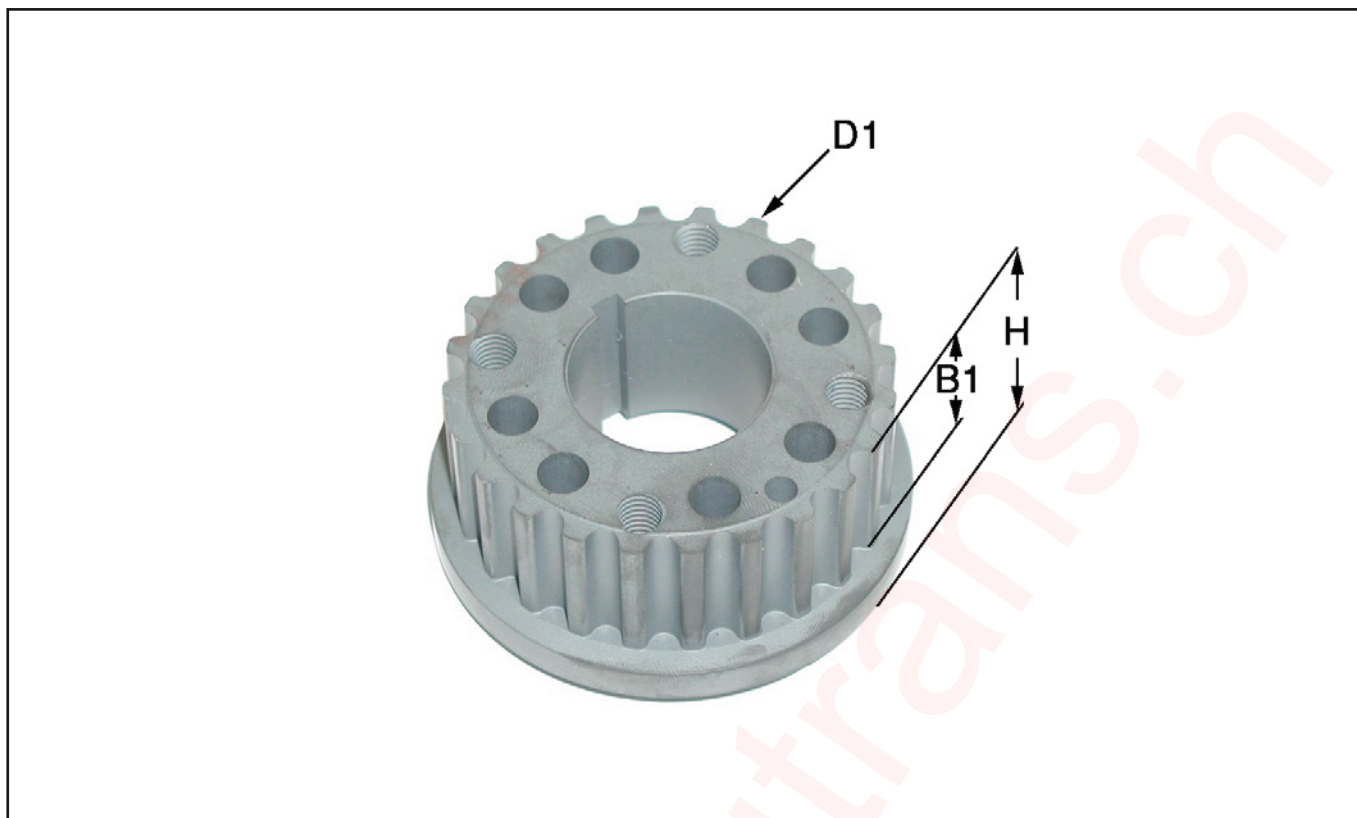

## DIMENSION OF MOUNTING HOLES

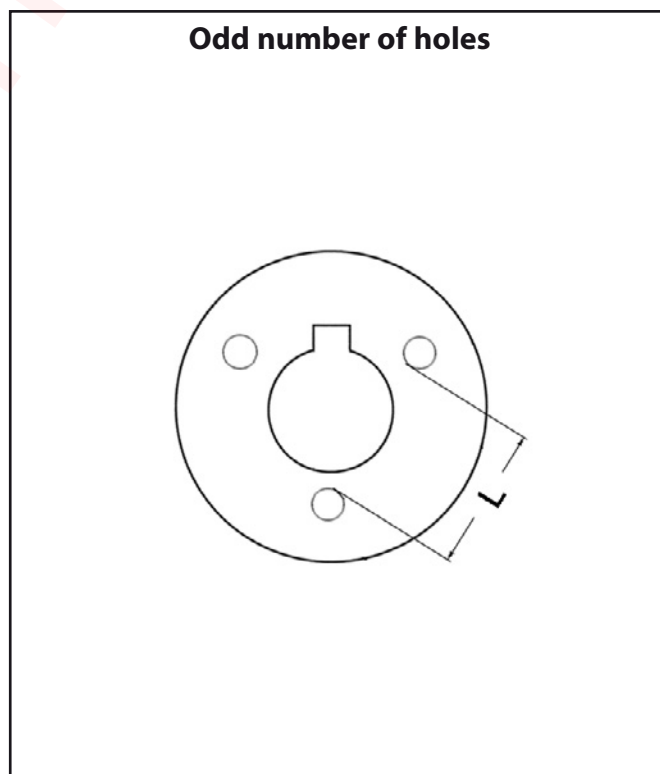
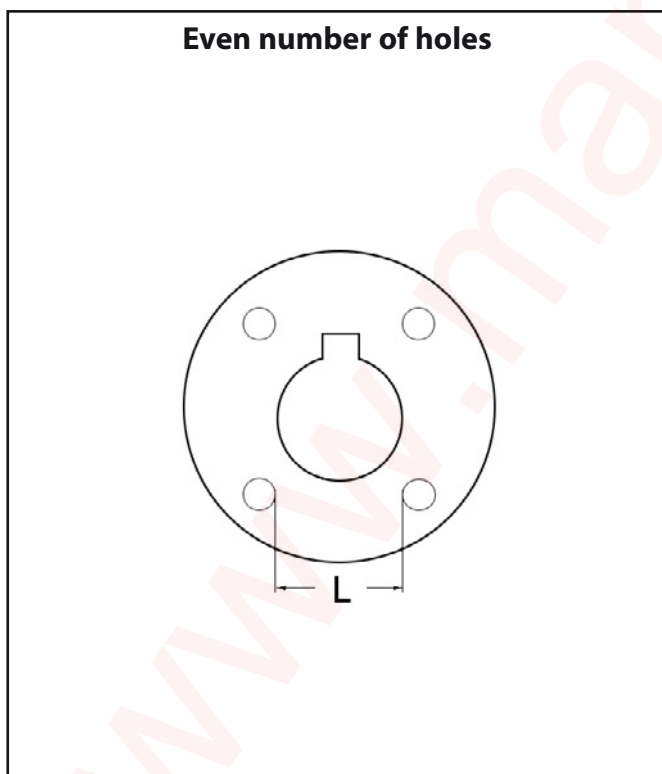

**NOTE:** this is not the centre distance, but the distance measured as per above pictures.

## INNER TYPES

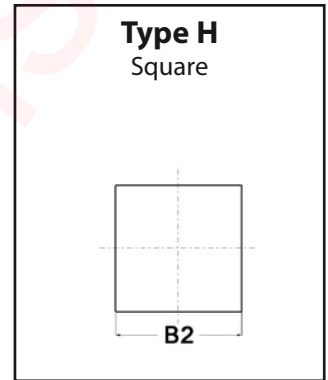
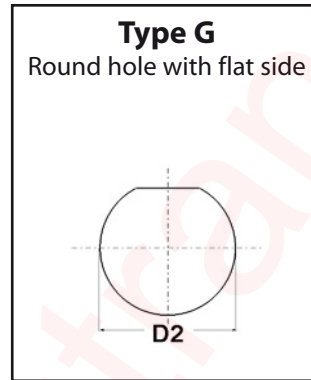
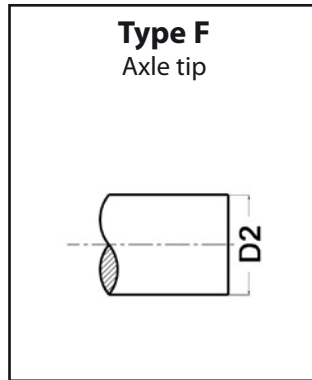
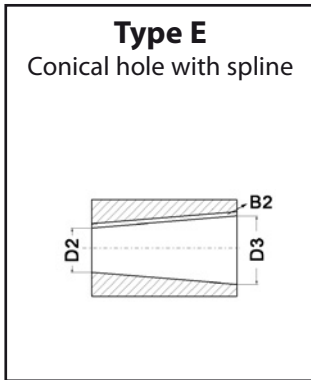
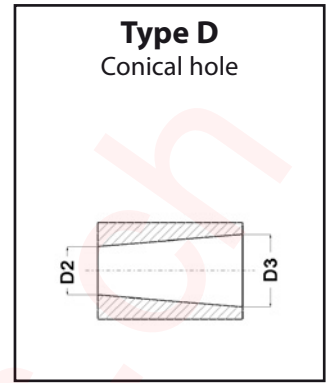
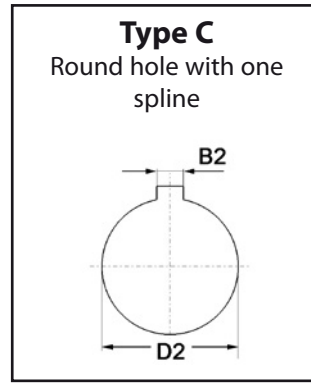
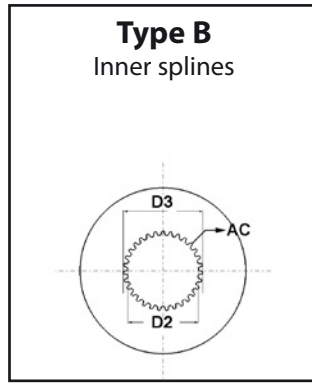
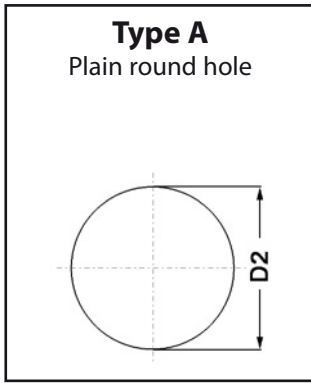

**Type S**  
Special type

If different inner types we determine the order as follow: B - D - C - A - E - F - G - H.  
E.g.: in case of 2 coexisting types D and A, we fill out D.

## DIAGRAM MEASUREMENT

When measuring an odd number of teeth, we place the fixed jaw of the sliding calliper onto 2 teeth and slide the jaw until it touches the opposite tooth.

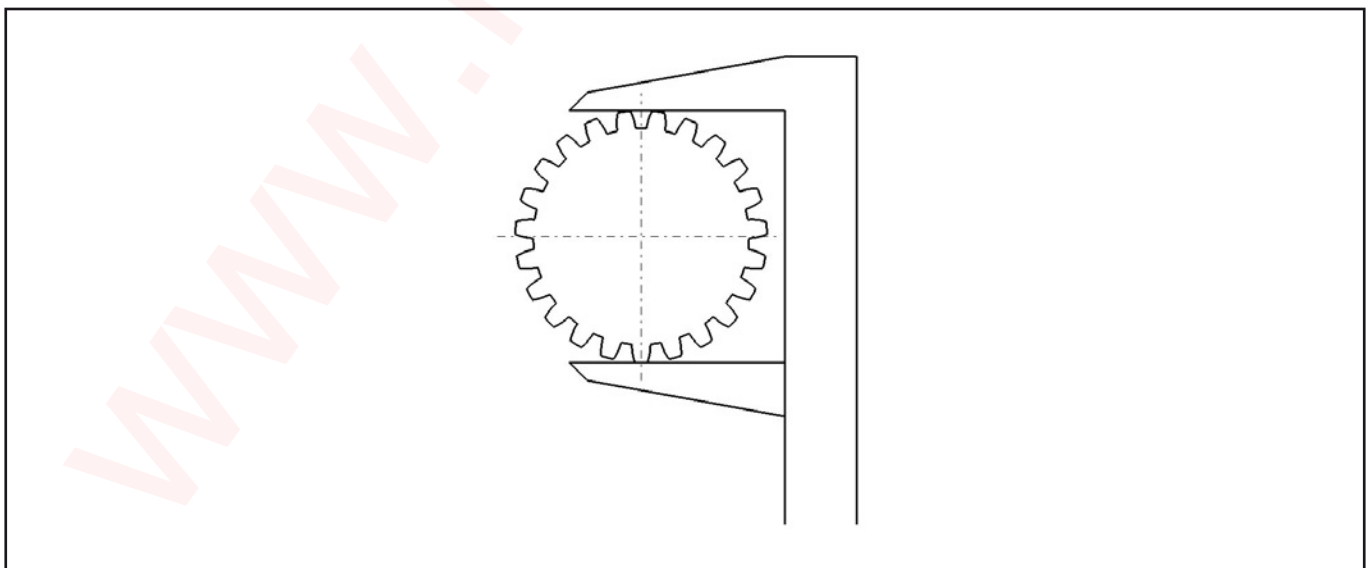

# TECHNISCHES DATENBLATT

## GEZÄHNTE RIEMENSCHIBE

Gruppe  
**01-03-04-04**

Beispiel



Kundendaten

Maschinentyp: .....

Preis Anfrage

Serien-Nr. Maschine: .....

Bestellung

CODE: D1 x B1 x Z x H x TY-BV x D2 x D3 x B2 x AC x AT-GA x D4 x L x TA x Pm x Pi x RH/LH

D1 ..... Durchmesser der Riemenscheibe.  
B1 ..... Zahnbreite.  
Z ..... Anzahl Zähne.  
H ..... Gesamthöhe.  
TY-BV ..... Innerer Befestigungstyp, siehe Typen.  
D2 ..... Maß, siehe innerer Befestigungstyp.  
D3 ..... Maß, siehe innerer Befestigungstyp.  
B2 ..... Maß, siehe innerer Befestigungstyp.  
AC ..... Nutenzahl innerer Befestigung.  
AT-GA ..... Befestigungslöcherzahl.  
D4 ..... Durchmesser Befestigungslöcher.  
L ..... Abstand, siehe Figur.  
TA ..... Gewindetyp der Befestigungslöcher.  
Pm ..... Gewinde (metrisch).  
Pi ..... Gewinde (Daum).  
RH/LH ..... Rechtes / linkes Gewinde.



**MANUTRANS** SA  
Fournitures pour engins de manutention

Manutrans SA  
Avenue de Lucens 44  
CH-1510 Moudon

Tél : +41 21 781 27 77  
Fax : +41 21 781 27 79  
info@manutrans.ch

## ABMESSUNGEN

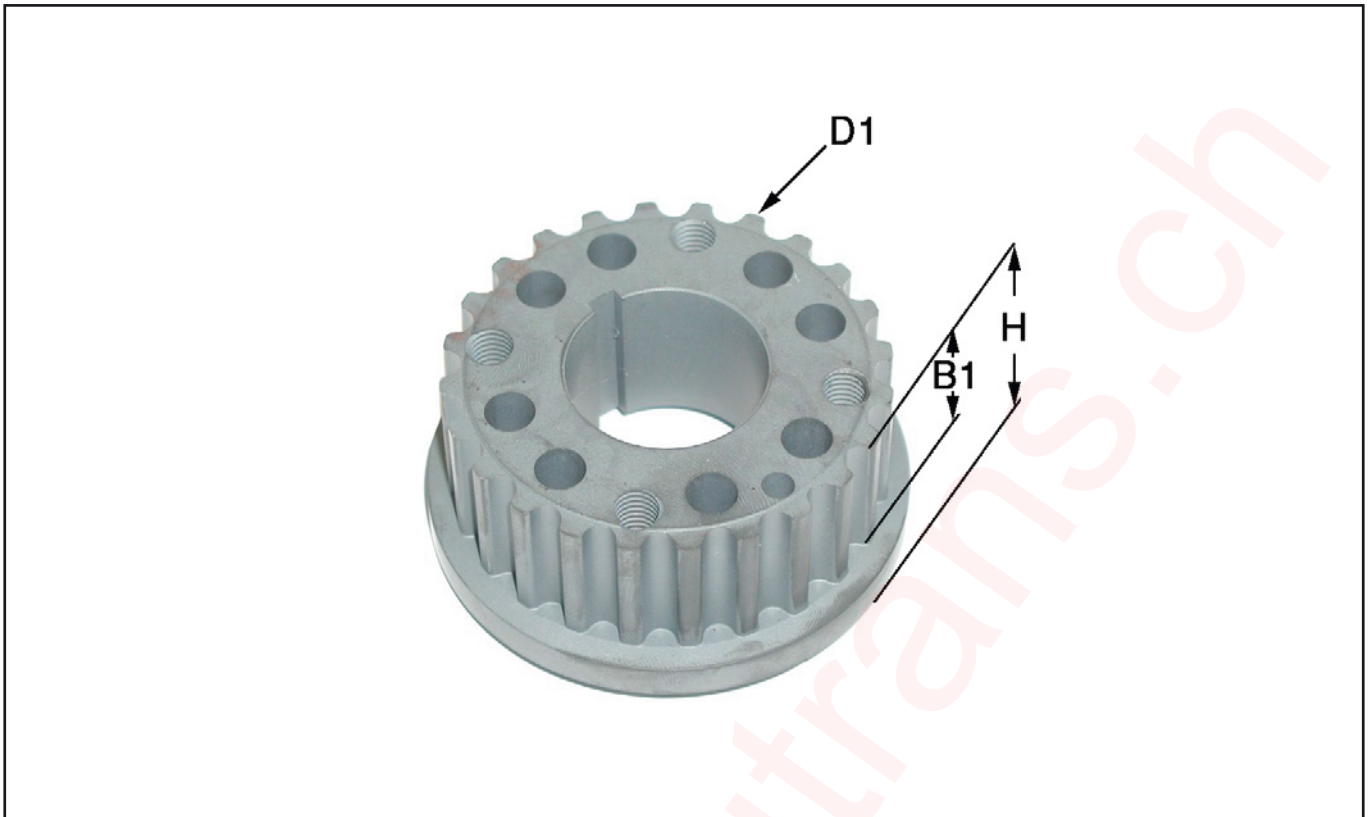

## ABMESSUNG BEFESTIGUNGSLÖCHER

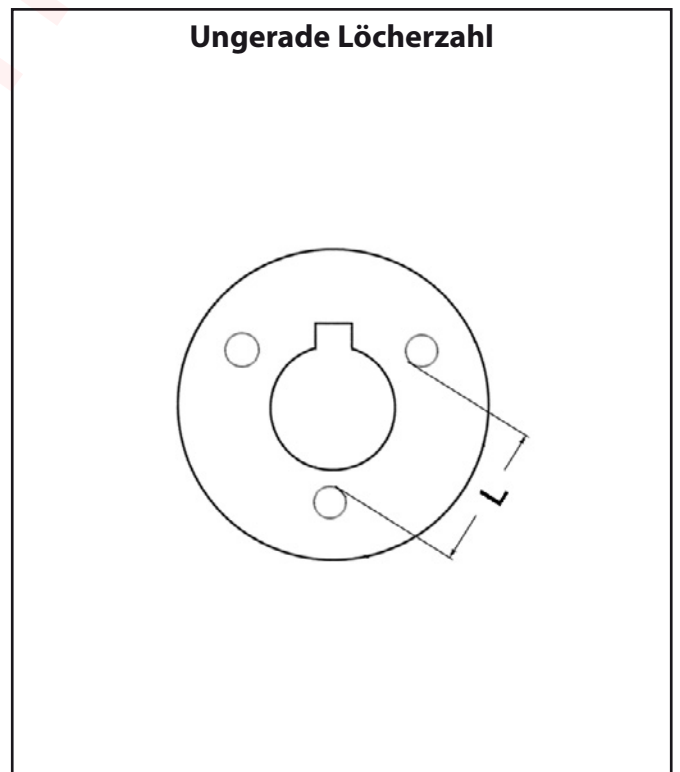
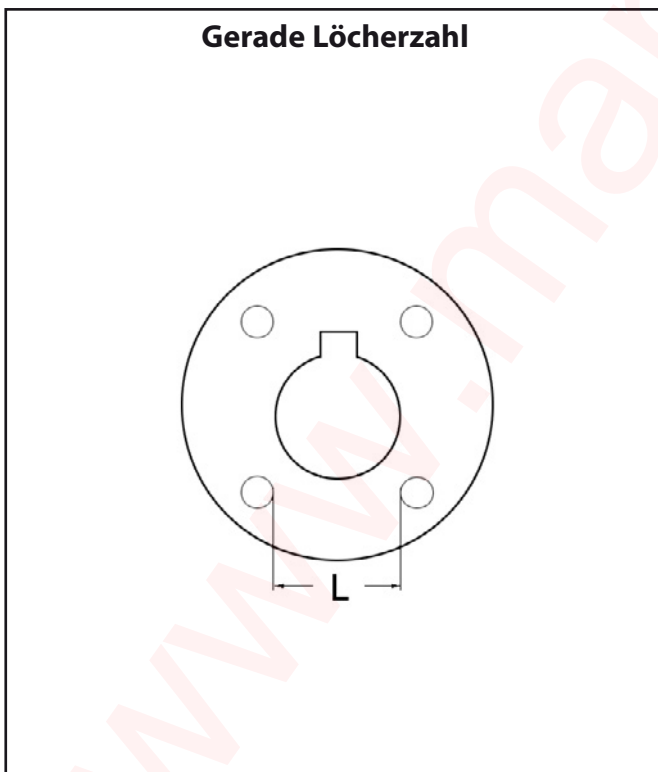

**BEMERKUNG:** Dies ist nicht der Mittenabstand, sondern der Abstand ausgemessen gemäß obenstehenden Schemen.



## INNENTYPEN

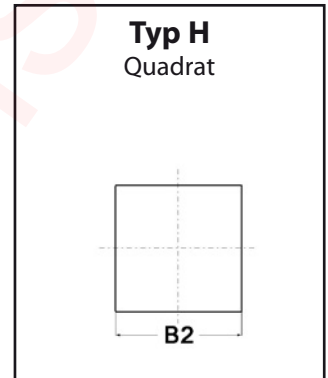
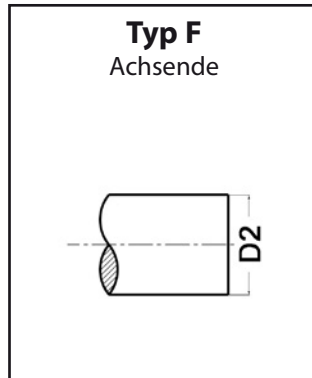
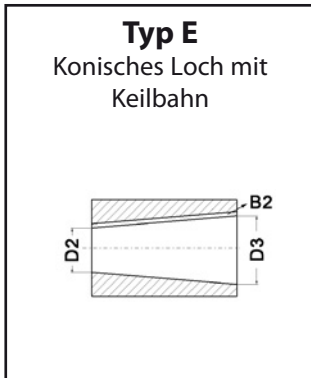
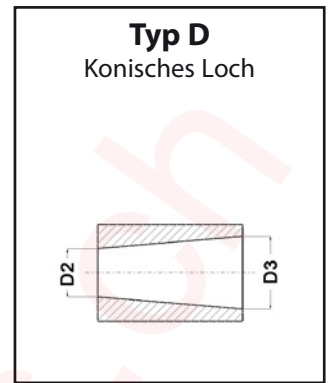
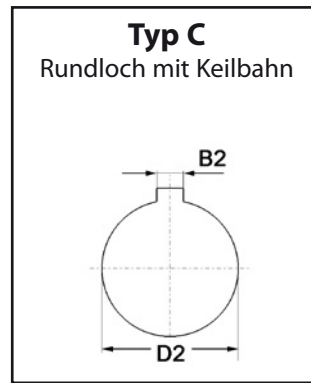
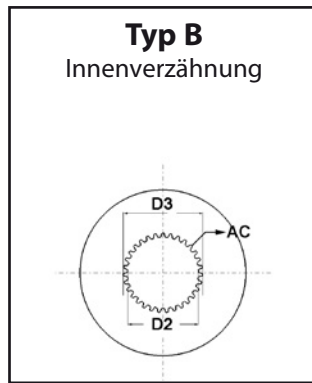
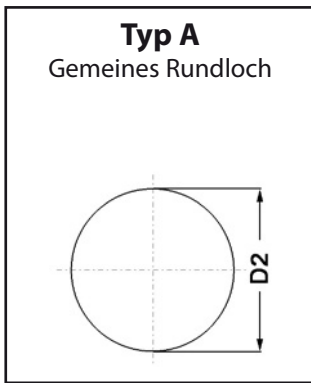

**Typ S**  
Sondertyp

Bei unterschiedlichen inneren Typen gibt es folgende Reihenfolge: B - D - C - A - E - F - G - H.  
z.B.: wenn die Typen D und A gleichzeitig vorkommen, muß der Typ D angegeben werden.

## SCHEMA AUSMESSUNG

Stecken Sie beim Ausmessen einer ungeraden Zähnezahl die feste Schublehrebacke auf 2 Zähne und schieben Sie die lockere Backe zu bis sie den gegenüberliegenden Zahn berührt.

