

FICHE TECHNIQUE

PIGNON DE CHAÎNE

Groupe
09-02-06-00

Exemple



Données client

Type machine :

Demande de prix

No. série machine :

Commande

CODE : TY-TW x D1 x B1 x Z x H x L x TY-BV x D2 x D3 x B2 x AC x LB

TY-TW..... Type de pignon de chaîne.

D1 Diamètre du pignon, selon mesure schéma.

B1..... Dimension.

Z..... Nombre de dents.

H..... Dimension, voir types.

L..... Dimensions entre les pignons, voir figure.

TY-BV Type de fixation interne.

D2 Dimension, voir types fixation interne.

D3 Dimension, voir types fixation interne.

B2..... Dimension, voir types fixation interne.

AC Nombre de cannelures fixation interne.

LB..... Palier ou bague : OUI/NON.

ATTENTION : en cas de présence de palier ou bague, prenez pour D2 le diamètre interne du palier ou bague.

DIMENSIONS

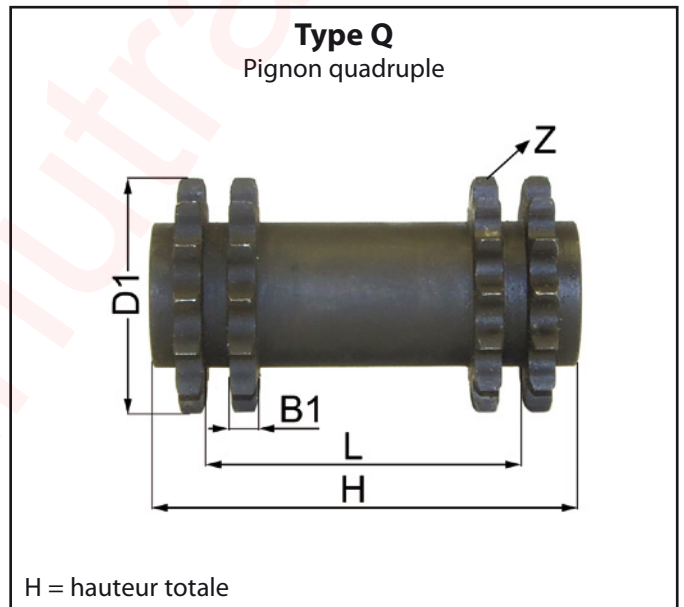
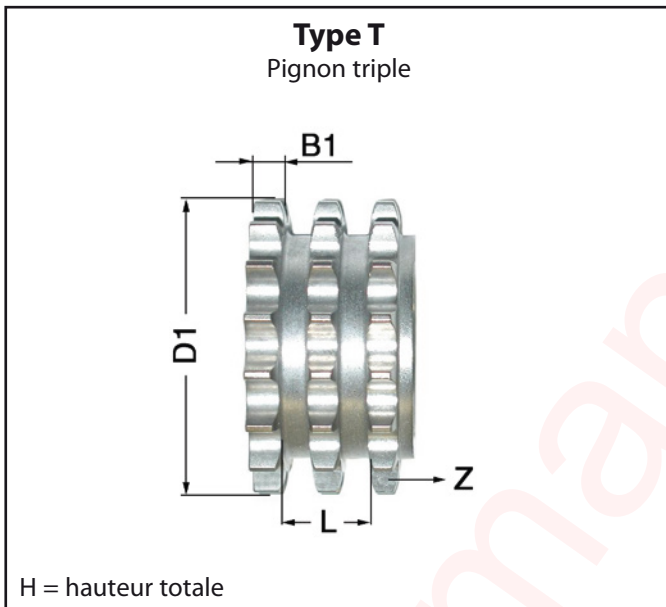
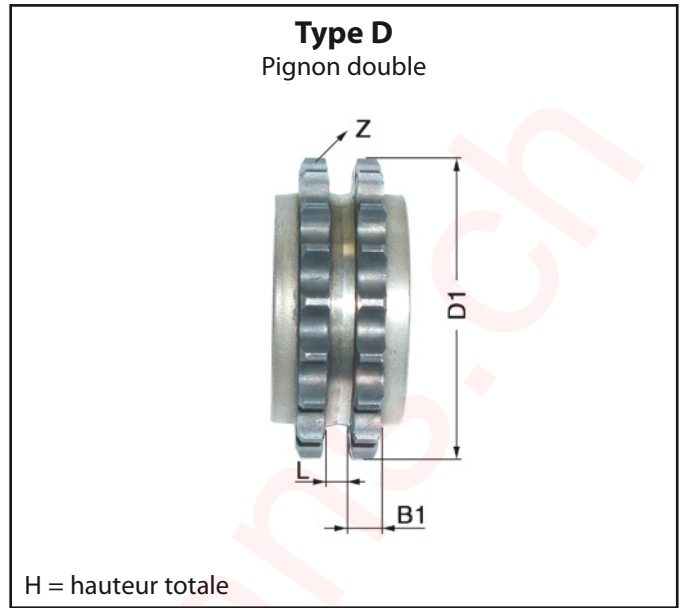
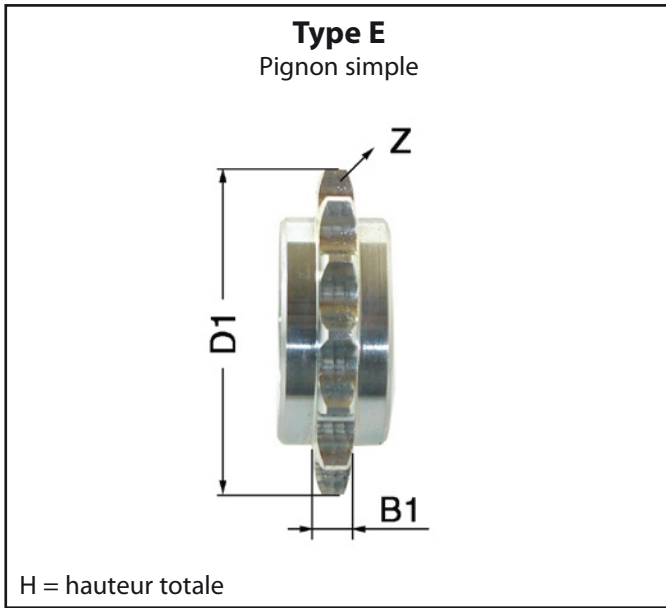

NOTE : si'il ya 2 différents pignons, mesurez le plus grand.

TYPES INTERNES

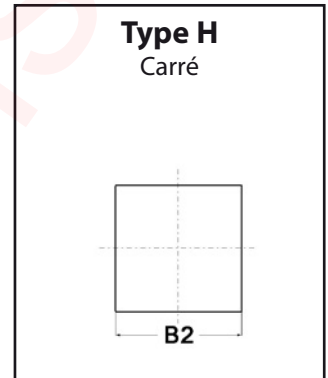
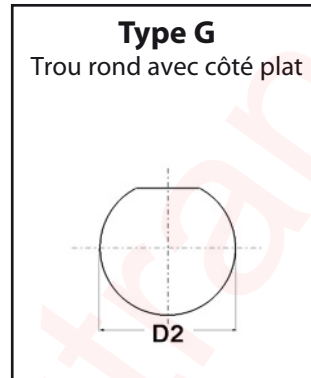
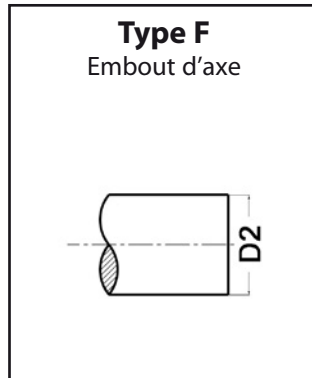
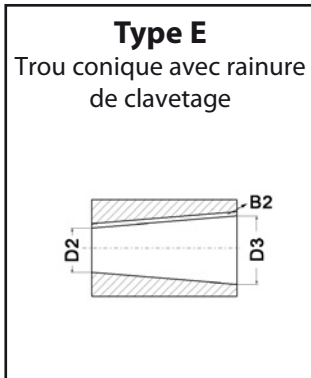
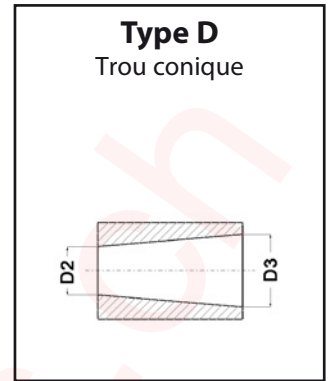
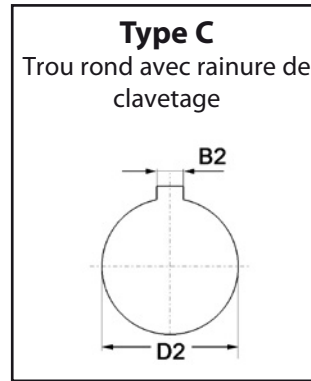
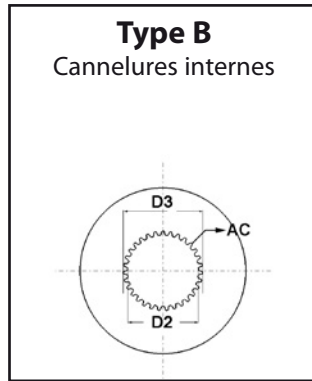
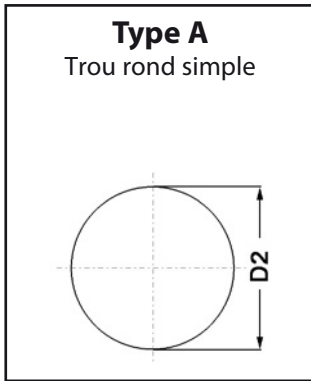

Type S
Type special

S'il y a plusieurs types internes, suivre l'ordre ci-dessous : B - D - C - A - E - F - G - H.
Ex: s'il y a présence en même temps de types D et A, remplissez D.

MESURER

Pour la mesure d'un nombre de dents impair, nous plaçons la mâchoire fixe du pied à coulisse sur deux dents et fermons la mâchoire mobile jusqu'à ce qu'elle atteigne une dent opposée.

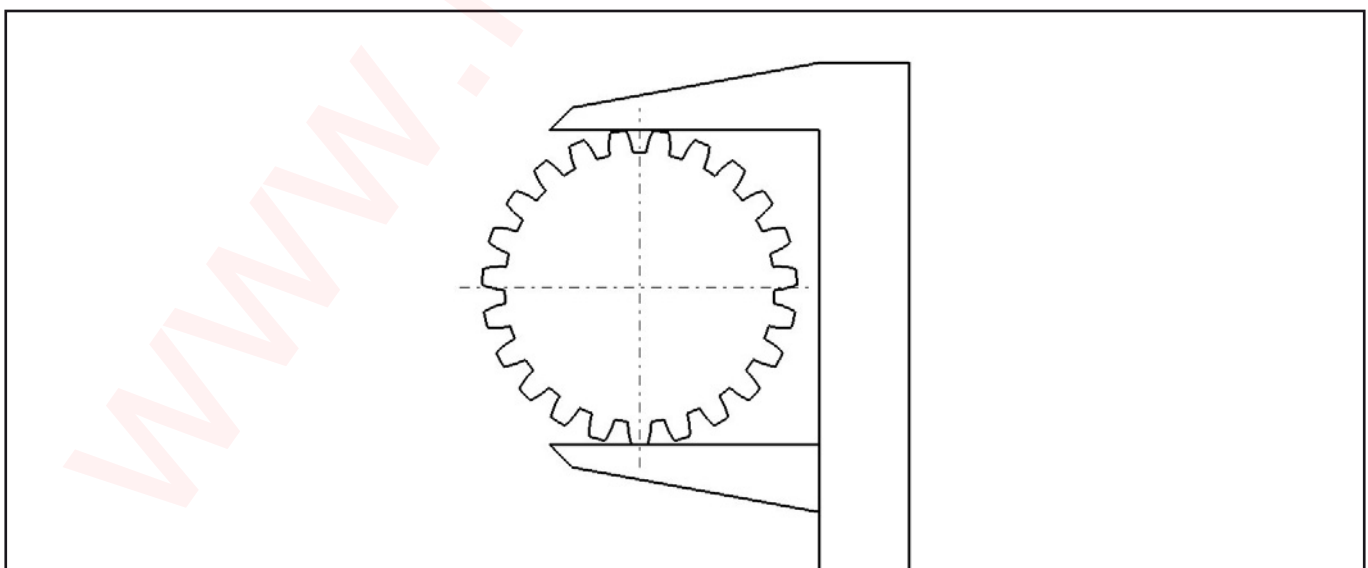

TECHNICAL SHEET

CHAIN GEAR

Group
09-02-06-00

Example



Customer details

Type machine:

Price inquiry

Serial n° machine:

Order

CODE: TY-TW x D1 x B1 x Z x H x L x TY-BV x D2 x D3 x B2 x AC x LB

TY-TW..... Type of chain gear.

D1 Diameter gear, as per measurement scheme.

B1..... Dimension.

Z..... Number of teeth.

H..... Dimension, see types.

L Dimension between gears, see picture.

TY-BV Type of inner mounting.

D2 Dimension, see types inner mounting.

D3 Dimension, see types inner mounting.

B2..... Dimension, see types inner mounting.

AC Number of splines inner mounting.

LB..... Bearing or bush: YES/NO.

ATTENTION: if bush or bearing, D2: inner diameter of bush or bearing.

DIMENSIONS

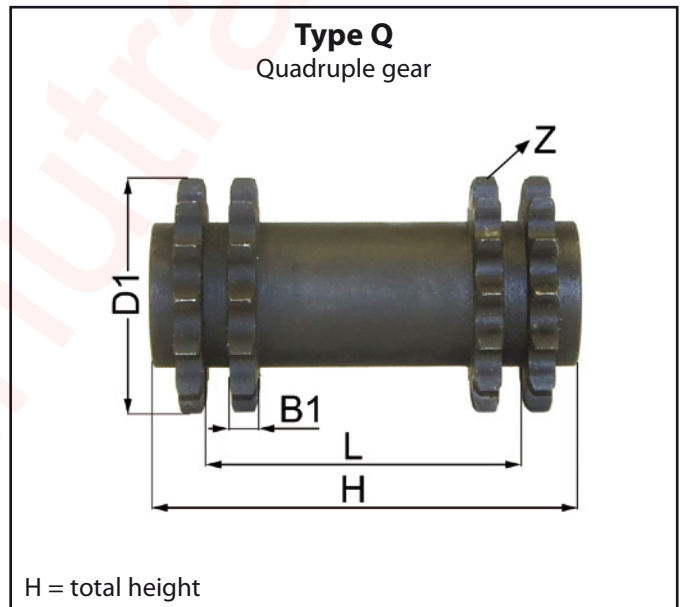
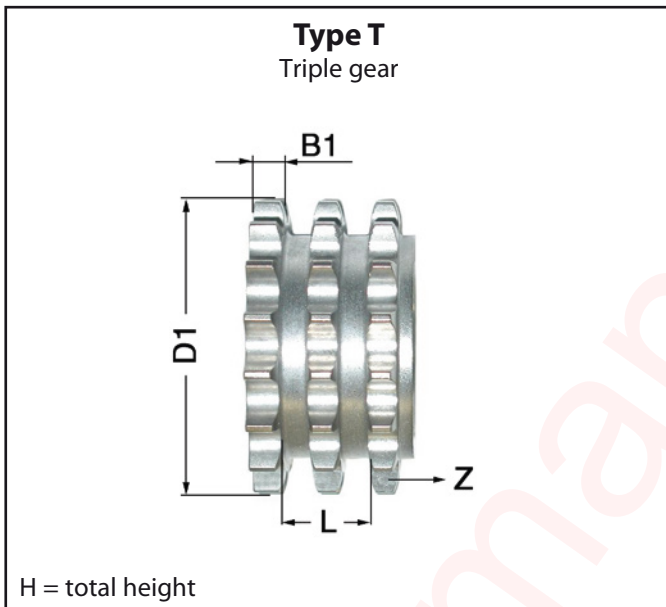
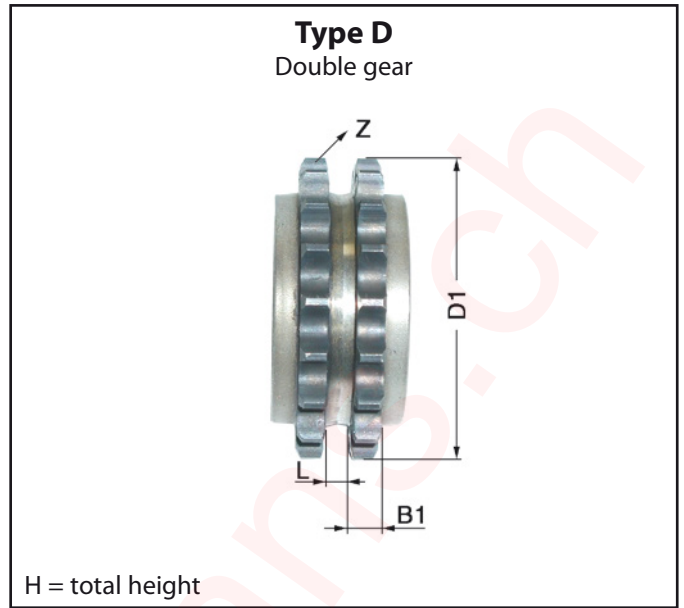
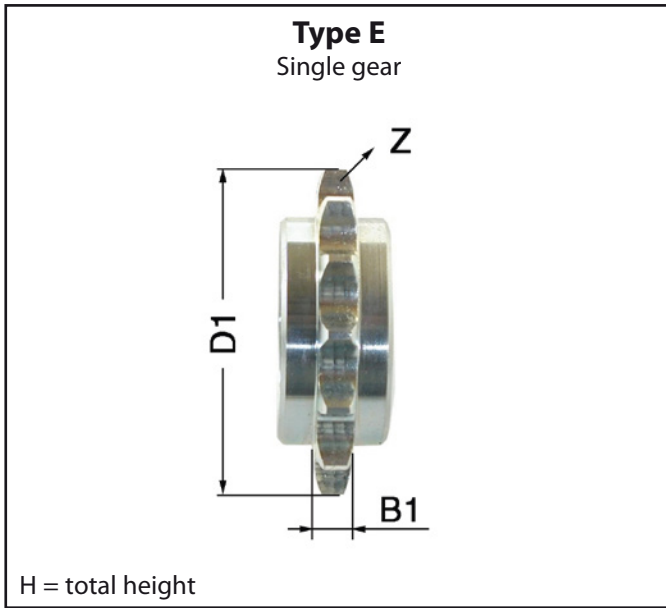

NOTE: if 2 different gears, measure the largest.

INNER TYPES

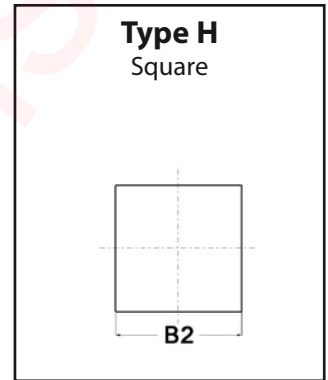
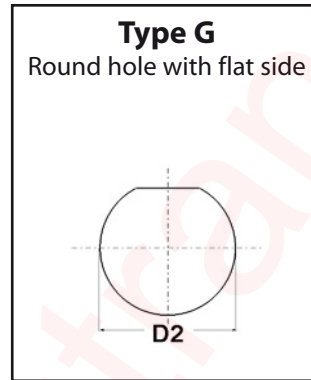
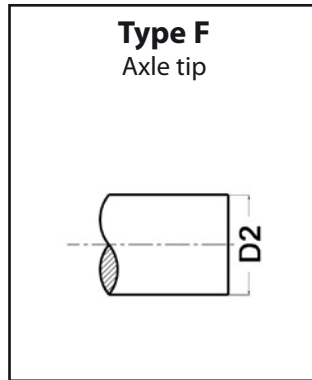
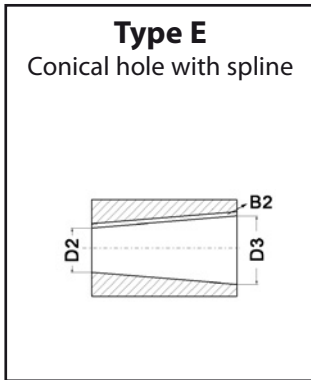
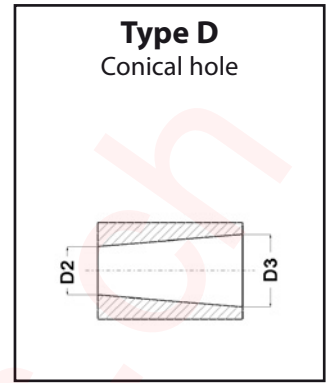
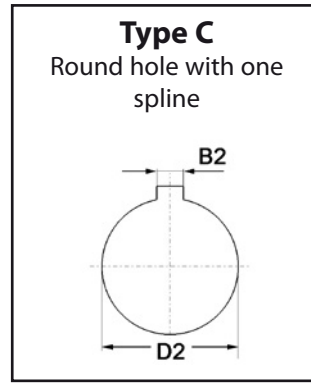
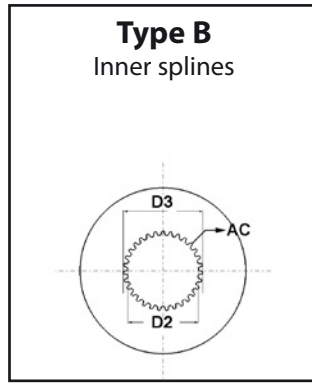
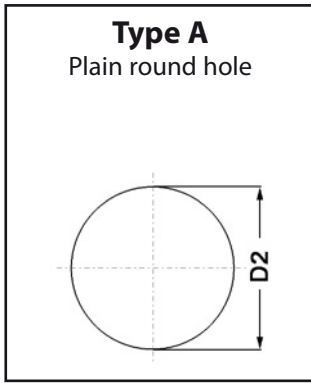

Type S
Special type

If different inner types we determine the order as follow: B - D - C - A - E - F - G - H.
E.g.: in case of 2 coexisting types D and A, we fill out D.

DIAGRAM MEASUREMENT

When measuring an odd number of teeth, we place the fixed jaw of the sliding calliper onto 2 teeth and slide the jaw until it touches the opposite tooth.

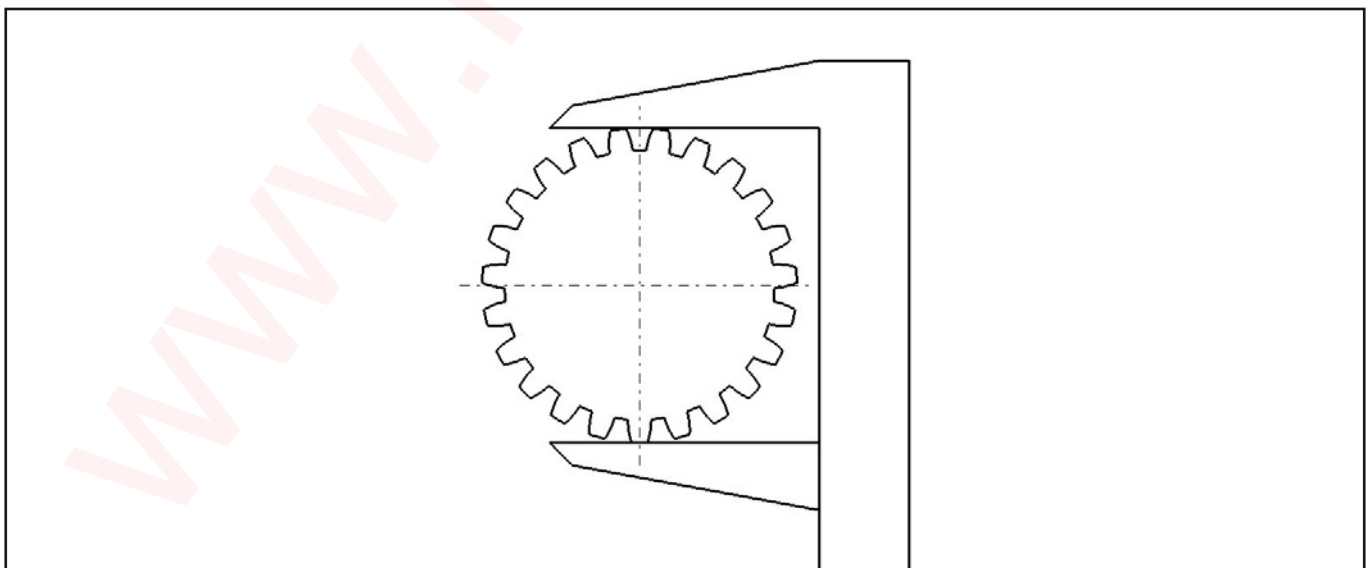

TECHNISCHES DATENBLATT

KETTENZAHNRAD

Gruppe
09-02-06-00

Beispiel



Kundendaten

Maschinentyp:

Preis Anfrage

Serien-Nr. Maschine:

Bestellung

CODE: TY-TW x D1 x B1 x Z x H x L x TY-BV x D2 x D3 x B2 x AC x LB

TY-TW..... Kettenzahnradtyp.

D1 Durchmesser Zahnrad, (siehe Schema).

B1..... Maß.

Z..... Anzahl Zähne.

H..... Maß, siehe Typen.

L Maß zwischen den Zahnradern, siehe Figur.

TY-BV Innerer Befestigungstyp.

D2 Maß, siehe innere Befestigungstypen.

D3 Maß, siehe innere Befestigungstypen.

B2..... Maß, siehe innere Befestigungstypen.

AC Verzählung innere Befestigung.

LB..... Lager oder Buchse vorhanden: JA/NEIN.

ACHTUNG: wenn ein Lager oder eine Buchse vorhanden ist, nehmen Sie für D2 den Innendurchmesser der Buchse oder des Lagers.



MANUTRANS SA

Fournitures pour engins de manutention

Manutrans SA
Avenue de Lucens 44
CH-1510 Moudon

Tél : +41 21 781 27 77
Fax : +41 21 781 27 79
info@manutrans.ch

ABMESSUNGEN

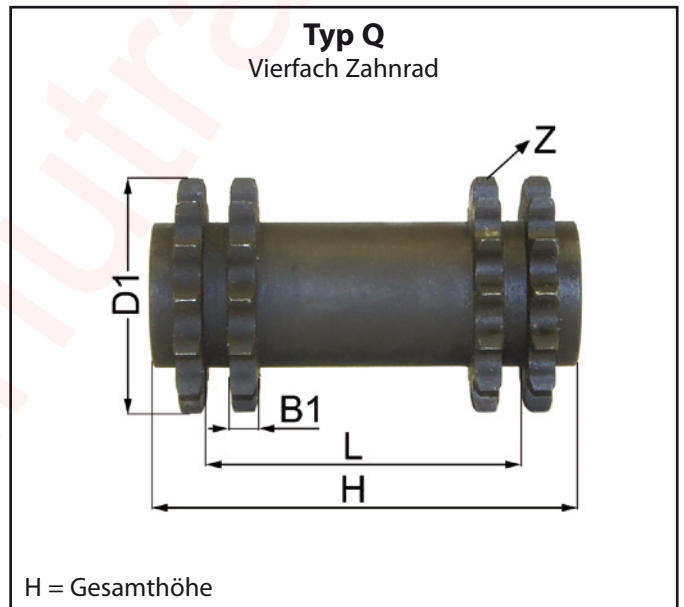
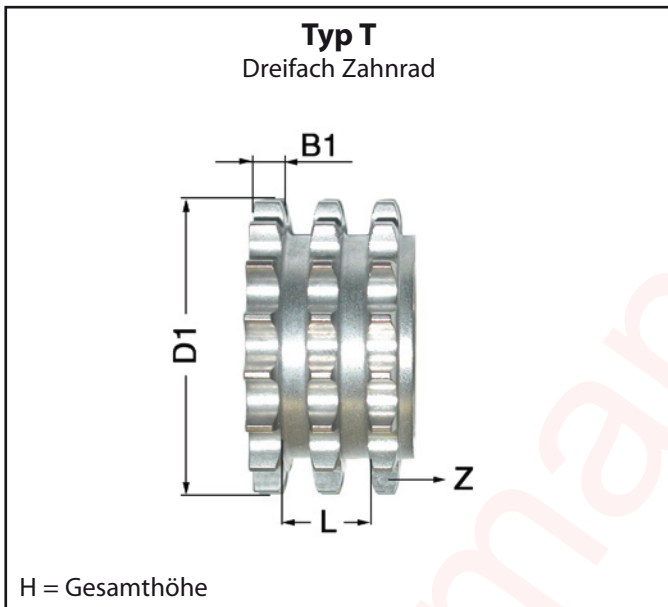
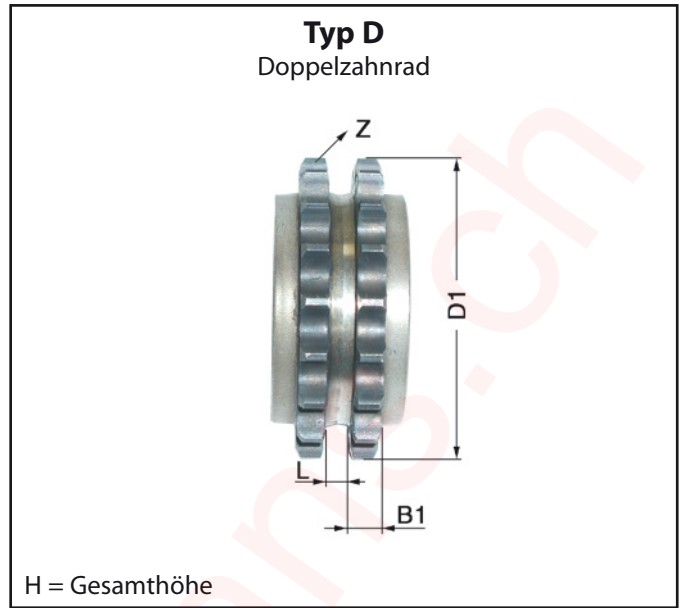
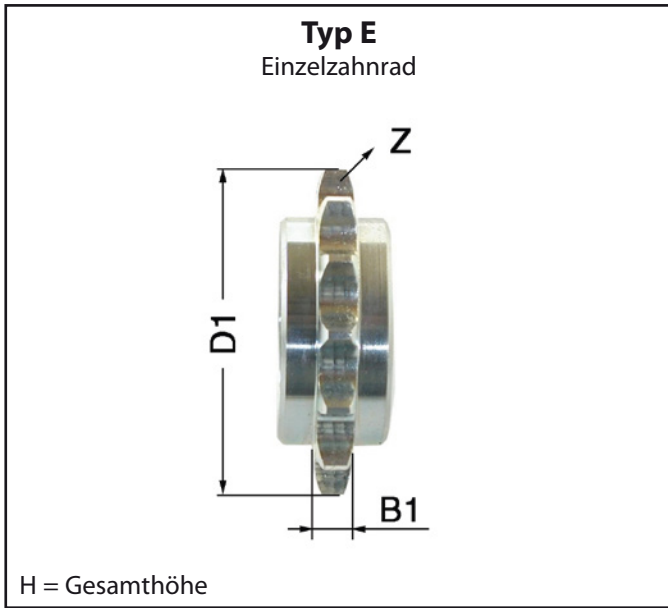

BEMERKUNG: bei 2 verschiedenen Zahnradern, messen Sie den Größten.

INNENTYPEN

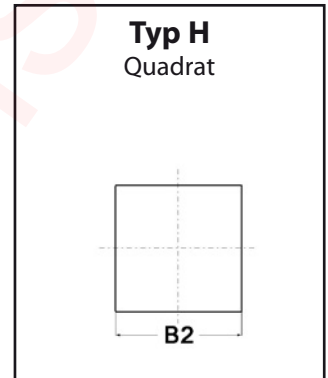
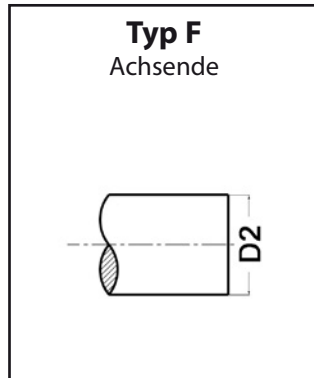
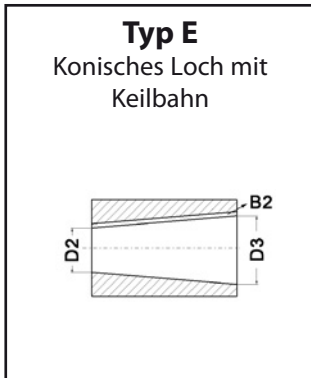
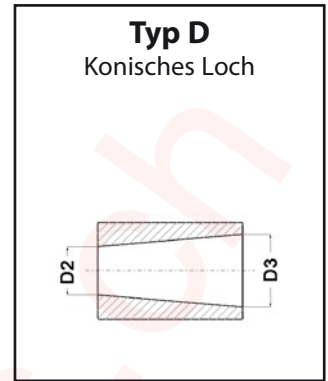
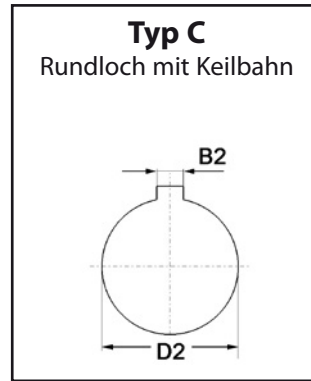
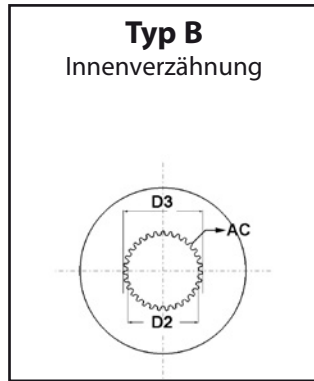
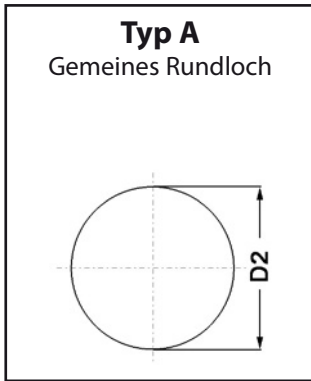

Typ S
Sondertyp

Bei unterschiedlichen inneren Typen gibt es folgende Reihenfolge: B - D - C - A - E - F - G - H.
z.B.: wenn die Typen D und A gleichzeitig vorkommen, mu der Typ D angegeben werden.

SCHEMA AUSMESSUNG

Stecken Sie beim Ausmessen einer ungeraden Zhnezahl die feste Schublehrebacke auf 2 Zhne und schieben Sie die lockere Backe zu bis sie den gegenberliegenden Zahn berhrt.

