

FICHE TECHNIQUE

PORTE-FOURCHE

Groupe
10-01-12-00

Exemple

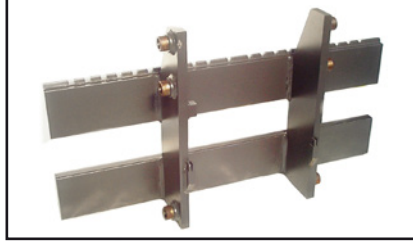

Données client

Type machine :

Demande de prix

No. série machine :

Commande

CODE : TY x A x B x FEM x C x C1 x C2 x C3 x C4 x M x E x E1 x F x F1 x AT-TA x D1 x D2 x I x J x K

- TY..... Type de porte-fourche, voir types.
A..... Longueur totale.
B..... Hauteur du porte-fourche.
FEM..... Type FEM.
C..... Hauteur des lattes transversales.
C1..... Entraxe entre l'axe de galet supérieur et le haut de la latte transversale.
C2..... Entraxe entre les axes de galets, voir figure.
C3..... Entraxe entre les axes de galets, voir figure.
C4..... Distance entre latte supérieure et haut de la latte transversale.
M..... Epaisseur de la latte transversale.
E..... Entraxe lattes transversales.
E1..... Distance entre les bases d'axes de galet, voir figure.
F..... Largeur des lattes transversales.
F1..... Distance entre le centre de l'axe et l'avant de la latte transversale.
AT-TA..... Nombre d'axes de galet.
D1..... Diamètre axes de galet.
D2..... Diamètre axe de galet spécial, si présent.
I..... Largeur de la latte supérieure.
J..... Épaisseur de la latte supérieure.
K..... Épaisseur des dents.

TYPES

Type A

Lattes supérieure et inférieure standard

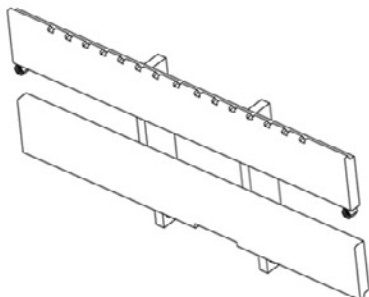

Type B

Latte supérieure fraisée et latte inférieure standard

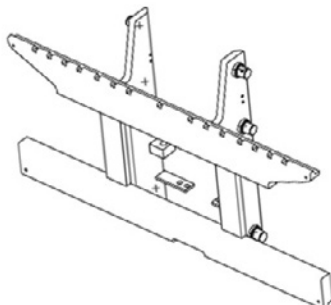

Type C

Lattes supérieure et inférieure fraisées

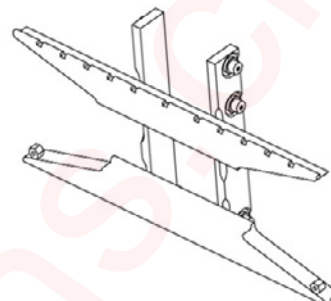

Type D

Encadrement soudé

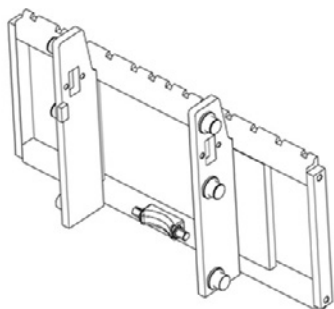

Type E

Découpe extérieure

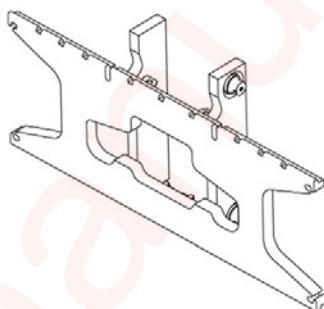

Type F

Découpe intérieure

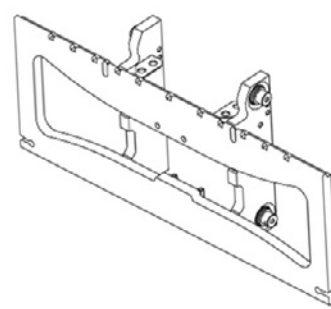

Type G

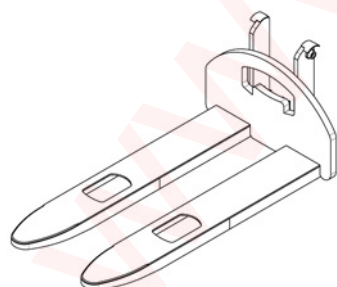

Type H

Porte fourche de translateur intégré

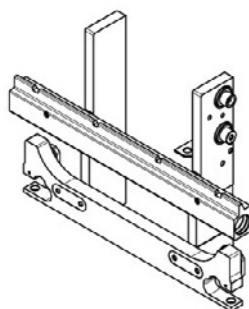

Type I

Cadre mobile de translateur intégré

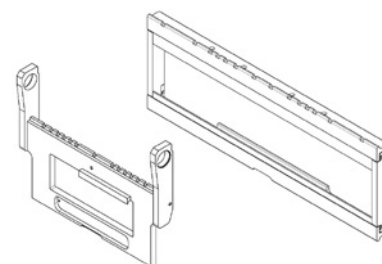

TECHNICAL SHEET

CARRIAGE

Group
10-01-12-00

Example

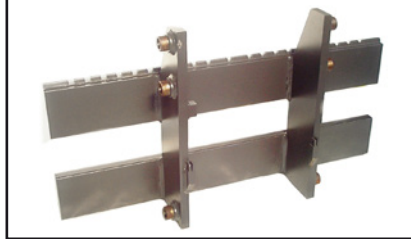

Customer details

Type machine:

Price inquiry

Serial n° machine:

Order

CODE: TY x A x B x FEM x C x C1 x C2 x C3 x C4 x M x E x E1 x F x F1 x AT-TA x D1 x D2 x I x J x K

- TY..... Type of carriage, see types
A..... Total length
B..... Height of carriage
FEM..... FEM type
C..... Highest cross bar
C1..... Centre distance between upper stud shaft and top side of cross bar
C2..... Centre distance between stud shafts, see drawing
C3..... Centre distance between stud shafts, see drawing
C4..... Distance between upper cross bar and top side of cross bar
M..... Thickness of cross bar
E..... Centre distance cross bar
E1..... Distance between bottom stud shaft and bottom stud shaft
F..... Width of cross bar
F1..... Distance between centre stud shaft and front side of cross bar
AT-TA..... Number of stud shaft
D1..... Diameter stud shaft
D2..... Diameter special stud shaft, if fitted
I..... Width of upper cross bar
J..... Thickness of upper cross bar
K..... Thickness of teeth

TYPES

Type A

Standard upper and lower cross bar

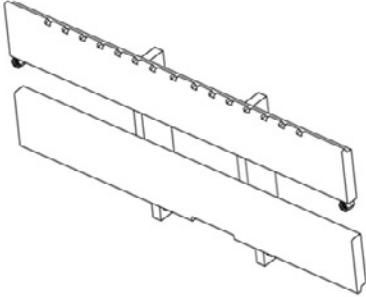

Type B

Milled upper bar standard lower bar

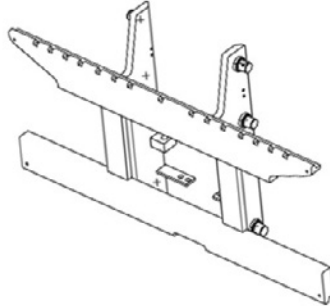

Type C

Milled upper and lower cross bar

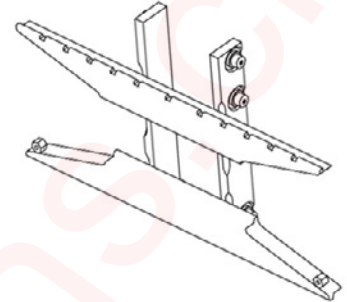

Type D

Welded frame

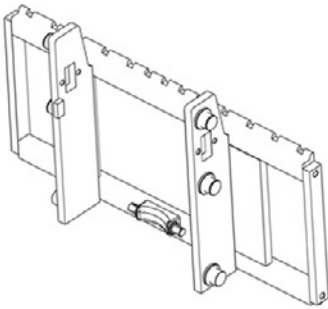

Type E

Outside cut

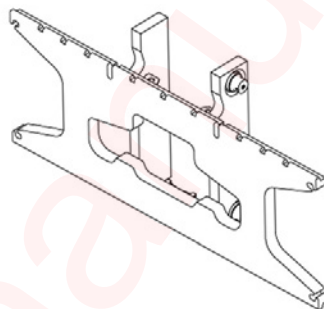

Type F

Inside cut

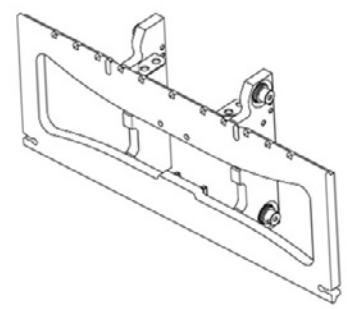

Type G

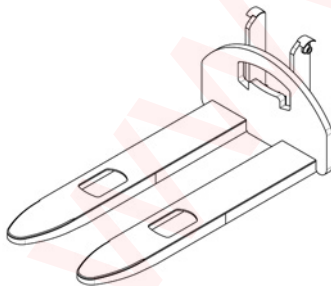

Type H

Fork carriage of integrated side shift

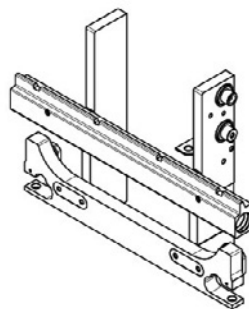

Type I

Movable frame of integrated side shift

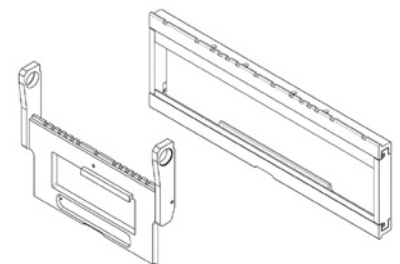

TECHNISCHES DATENBLATT

GABELTRÄGER

Gruppe
10-01-12-00

Beispiel

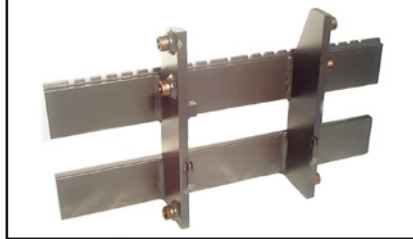

Kundendaten

Maschinentyp:

Preis-anfrage

Serien-Nr. Maschine:

Bestellung

CODE: TY x A x B x FEM x C x C1 x C2 x C3 x C4 x M x E x E1 x F x F1 x AT-TA x D1 x D2 x I x J x K

TY..... Gabelträgartyp, siehe Typen.

A..... Gesamtlänge.

B..... Höhe Gabelträgartyp.

FEM..... FEM-Typ.

C..... Höhe der Querlatte.

C1..... Zenterabstand zwischen dem oberen Zapfen und der oberen Seite der Querlatte.

C2..... Zenterabstand zwischen Zapfen, siehe Abbildung.

C3..... Zenterabstand zwischen Zapfen, siehe Abbildung.

C4..... Abstand zwischen der oberen Latte und der oberen Seite der Querlatte.

M..... Dicke Querlatte.

E..... Zenterabstand Querlatte.

E1..... Abstand zwischen den beiden Zapfen unten.

F..... Breite Querlatte.

F1..... Abstand zwischen Zentrum Zapfen und Vorderseite Querlatte.

AT-TA..... Anzahl der Zapfen.

D1..... Durchmesser Zapfen.

D2..... Durchmesser Sonderzapfen, wenn vorhanden.

I..... Breite der oberen Latte.

J..... Dicke der oberen Latte.

K..... Dicke der Zähne.

TYPEN

Typ A

Standard obere und untere Latte

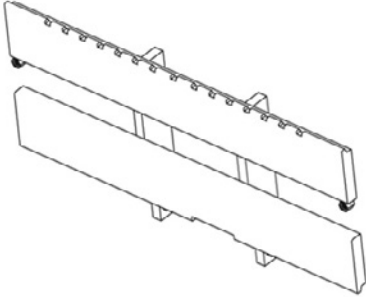

Typ B

Gefräste obere latte und
standard untere Latte

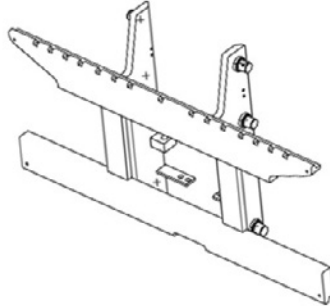

Typ C

Gefräste obere und untere Latte

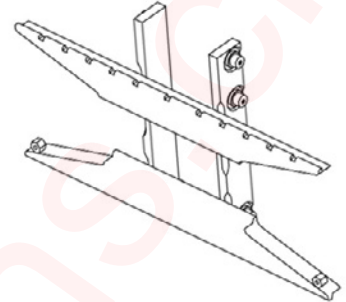

Typ D

Geschweißter rahmen

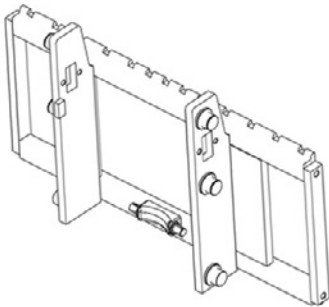

Typ E

Außeres Brennstück

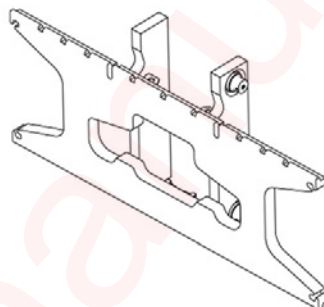

Typ F

Inneres Brennstück

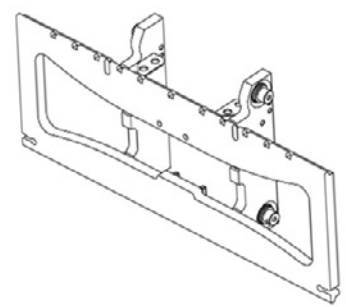

Typ G

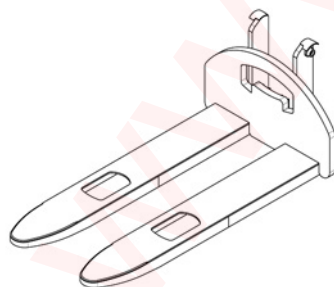

Typ H

Gabelträger von
integriertem Seitenschieber

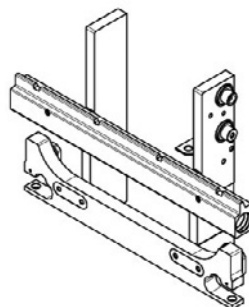

Typ I

Bewegbarer rahmen von
integriertem Seitenschieber

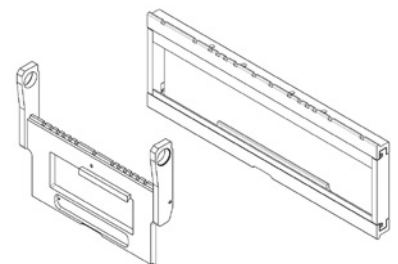

AFMETINGEN/DIMENSIONS/ABMESSUNGEN

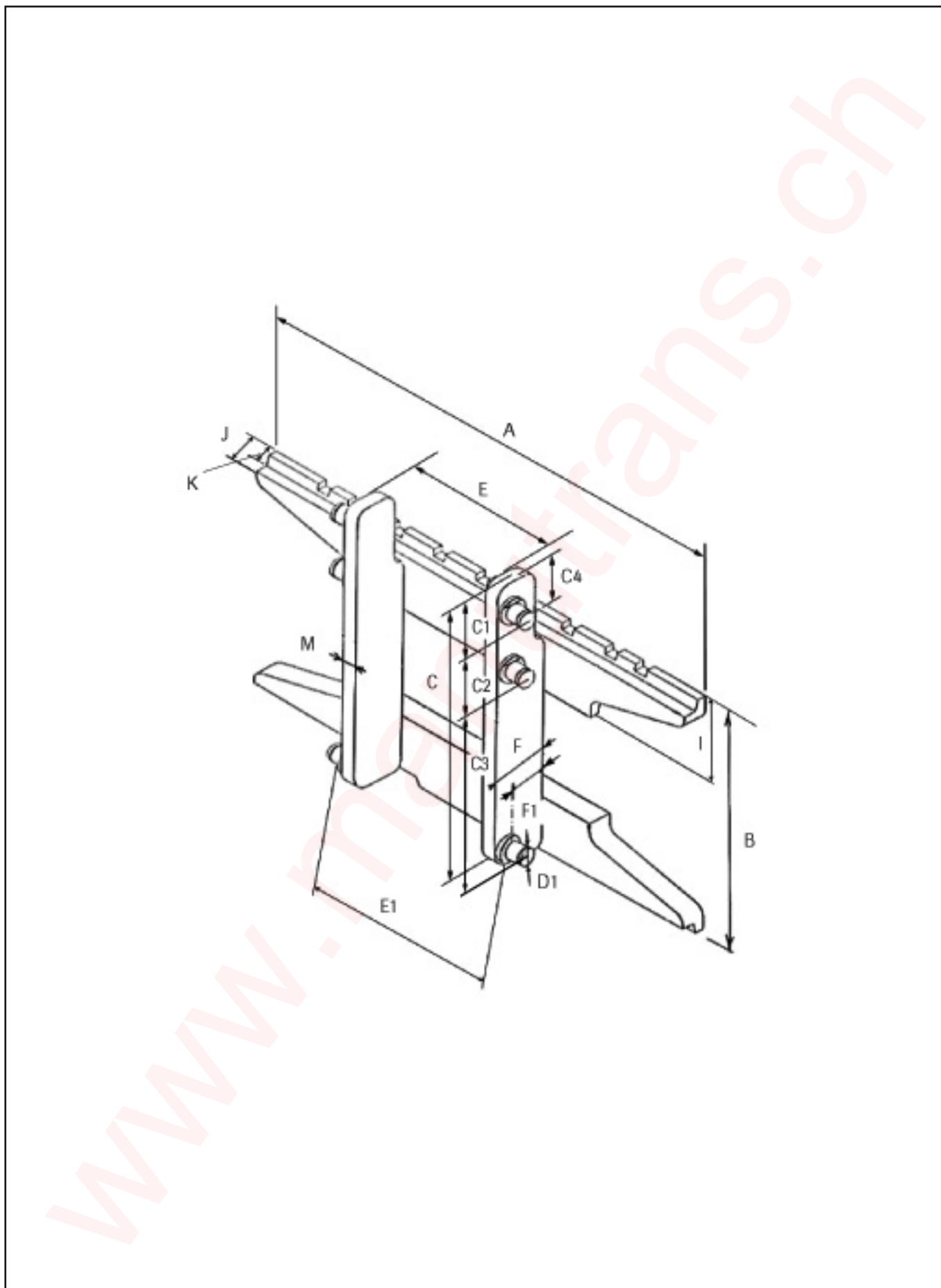

MANUTRANS SA

Fournitures pour engins de manutention

Manutrans SA
Avenue de Lucens 44
CH-1510 Moudon

Tél : +41 21 781 27 77
Fax : +41 21 781 27 79
info@manutrans.ch