

FICHE TECHNIQUE

ARBRE À VIS SANS FIN

Groupe
12-01-02-00

Exemple



Données client

Type machine :

Demande de prix

No. série machine :

Commande

CODE : L1 x D x L2 X AT-TA

L1..... Longueur totale.

D..... Diamètre arbre.

L2..... Longueur du filetage.

AT-TA..... Nombre de dents (s'il y a une roue dentée).

DIMENSIONS

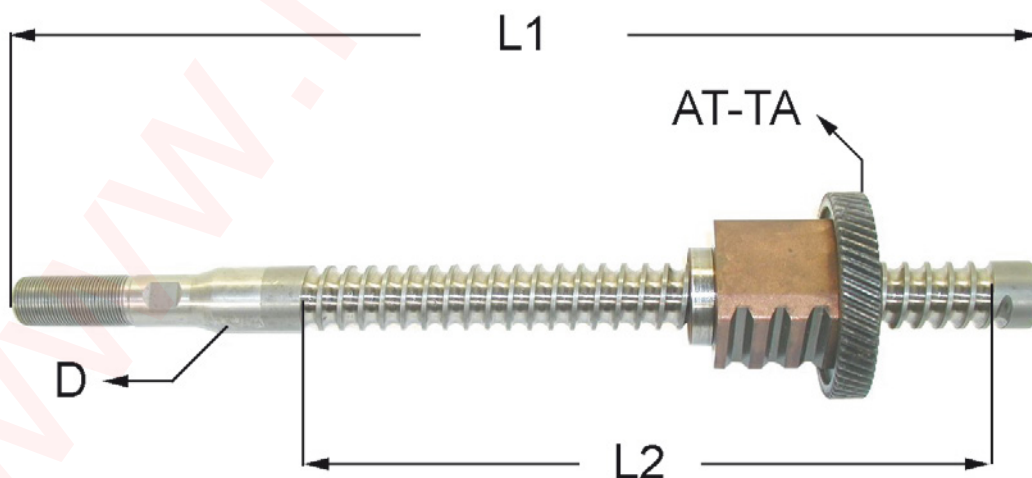

TECHNICAL SHEET

SCREWBALL SHAFT

Group
12-01-02-00

Example



Customer details

Type machine:

Price inquiry

Serial n° machine:

Order

CODE: L1 x D x L2 X AT-TA

L1..... Total length.

D..... Diameter.

L2..... Length of the screw ball.

AT-TA..... Number of teeth (if applicable).

DIMENSIONS

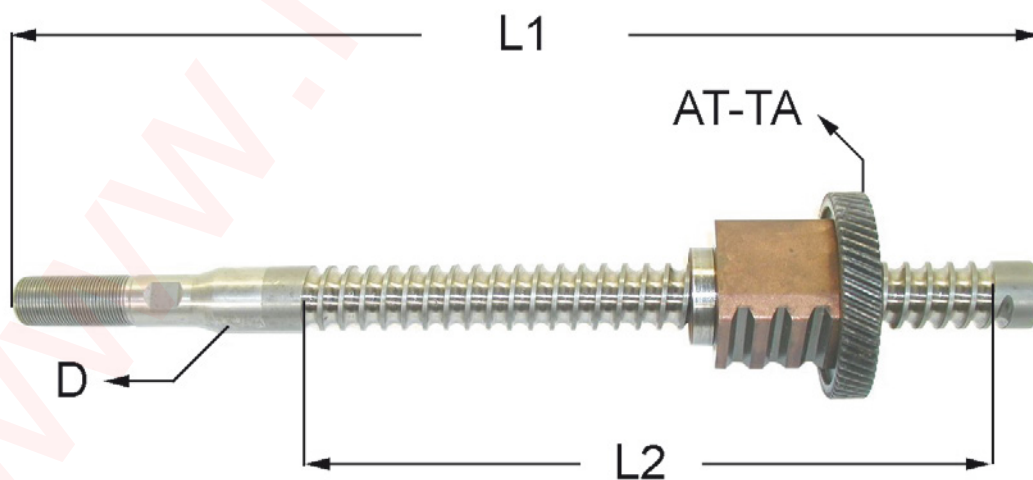

TECHNISCHES DATENBLATT

LENKGETRIEBE MECH. AT

Gruppe
12-01-02-00

Beispiel



Kundendaten

Maschinentyp:

Preis-anfrage

Serien-Nr. Maschine:

Bestellung

CODE: L1 x D x L2 X AT-TA

L1..... Gesamtlänge.

D..... Achsendurchmesser.

L2..... Länge der Lenkschnecke.

AT-TA..... Zähnezahl (wenn ein Zahnrad vorhanden ist).

ABMESSUNGEN

